

High Pressure Valve

Series 4140

Features

- ▶ Original Shear-Seal® technology
- ▶ All stainless steel construction
- ▶ SAE porting standard
- ▶ NPT porting available
- ▶ Pressures to 15,000 psi
- ▶ Low pressure drop
- ▶ Low handle load
- ▶ Actuator available

Applications

- ▶ Offshore drilling equipment
- ▶ Refineries and chemical processing plants
- ▶ Gas compression systems
- ▶ Marine umbilical reels



General Specifications*

Working Pressure:	10,000 psi (700 bar) standard 15,000 psi option with appropriate port size and port type
Flow Capacity, Cv:	See table
Back Pressure:	Must not exceed 250 psi (17.2 bar) at return port for satisfactory operation
Pressure Drop:	14 psi (0.96 bar) at 20 ft/s
Proof Pressure:	1-1/2 times working pressure except at return port
Burst Pressure:	2-1/2 times working pressure except at return port (3,000 psi [206 bar]) maximum

Media Temperature Range:	-40° to +250°F (-40° to +121°C)
Rotor:	400 series stainless steel
Pressure Seals:	Stainless steel
Shaft:	Stainless steel
All External Components:	300 series stainless steel
Standard O-ring:	Buna N
Back-up Rings:	Teflon®

* See product configurator for additional options and Supplemental Guide for more detailed information.

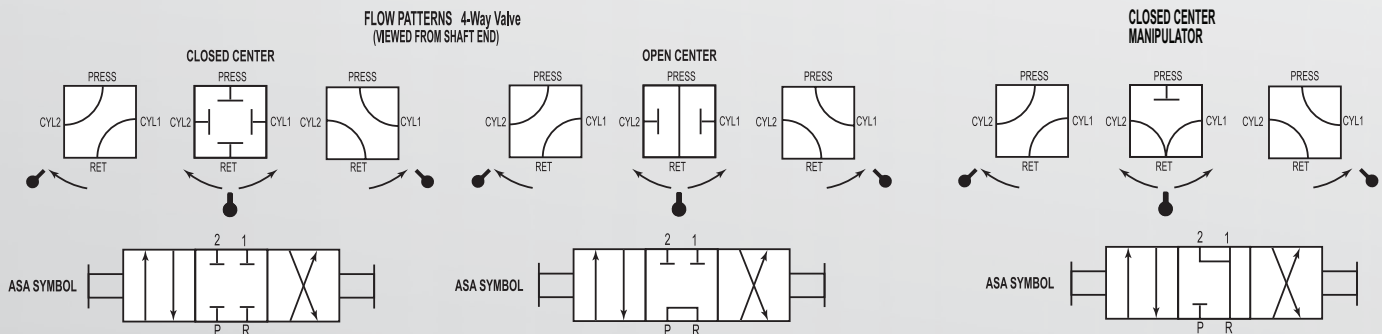

Main Valve Port Size	Flow Capacity (Approx.)			Min. Flow Passage Dia.	Cv Factor	Approx. Shipping Weight lbs (kgs)
	20 ft/sec gpm (l/min)	40 ft/sec gpm (l/min)	60 ft/sec gpm (l/min)			
1/4" or SAE-4	4 (15)	8 (30)	12 (45)	9/32"	0.95	13.5 (6.2)
3/8" or SAE-6	4 (15)	8 (30)	12 (45)	9/32"	0.95	13.5 (6.2)
1/2" or SAE-8	4 (15)	8 (30)	12 (45)	9/32"	0.95	13.5 (6.2)

Barksdale
CONTROL PRODUCTS

Barksdale, Inc./Barksdale GmbH
A Subsidiary of Crane Co.

High Pressure Valve

Series 4140

Technical Drawings

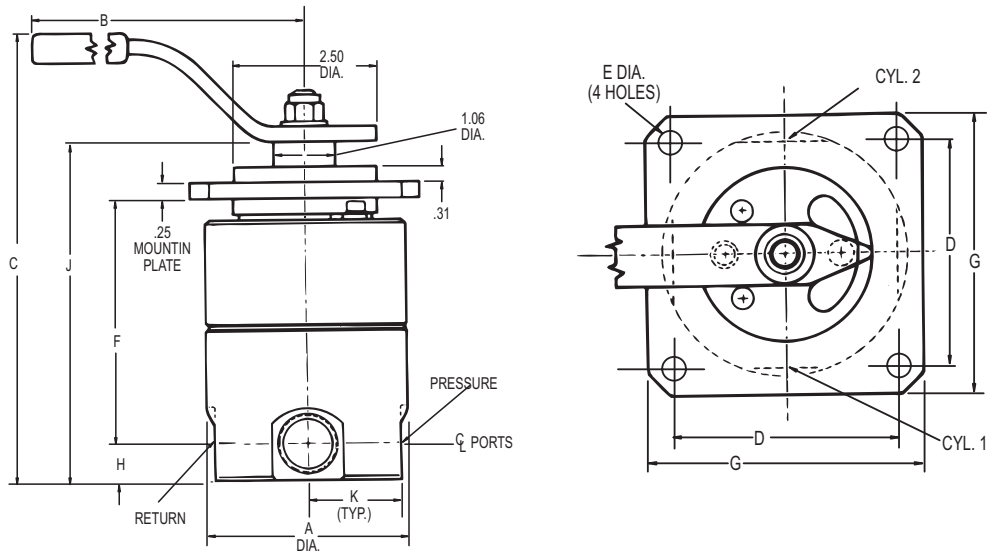

Port Size	A Dia.	B	C	D	E Dia.	F	G	H	J	K
1/4" or SAE-4	3.50 (89)	7.00 (178)	7.69 (195)	3.25 (83)	0.28 (7)	4.22 (107)	4.00 (102)	0.63 (16)	5.81(148)	1.63 (41)
3/8" or SAE-6	3.50 (89)	7.00 (178)	7.69 (195)	3.25 (83)	0.28 (7)	4.22 (107)	4.00 (102)	0.63 (16)	5.81(148)	1.63 (41)
1/2" or SAE-8	3.50 (89)	7.00 (178)	7.69 (195)	3.25 (83)	0.28 (7)	4.22 (107)	4.00 (102)	0.63 (16)	5.81(148)	1.63 (41)

Product Configurator

Example: **414 1 R 9 W C 3 -MS**

Series

414 Basic 3 position 4 way

Port Size

- 1 1/4" NPT ports
- 2 3/8" NPT ports
- 3 1/2" NPT ports

Style

R Regular (side) porting

Operating Pressure

9 10,000 psi

Service

W Lubricated water or hydraulic oil

Flow Pattern

- C Closed center
- O Open center (tandem center)
- Q Closed center manipulator (float center)
(Not available in 15,000 psi)

Options

-MC	Spring centering
	15,000 psi
-O	Size Type
	1/4" NPT, MS, MP
	3/8" MS, MP
	1/2" MS, MP

Port Type

blank	NPT porting
-MS	SAE J1926 porting
-MP	Medium pressure porting (1/2" is actually 9/16")

Position

3 Three position